

Case Study: Enterprise Data Center Retrofit

Phoenix-based Arizona Facilities Services retrofits an aging enterprise data center for substantial energy savings plus comprehensive visibility and control of all building systems.

The Challenge

An enterprise data center (EDC) is a secure, climate-controlled building that houses mission-critical back-end computer systems for businesses and organizations. EDCs aren't the massive Internet data centers with thousands of computer servers that power today's online services and cloud computing, but instead are smaller and more centralized facilities that have supported important computer systems and stored crucial data for decades. And today, EDCs continue in their critical role for enterprises and organizations worldwide.

Long before the initial commercial use of the Internet in the early 1990s, computer systems running securely in EDCs made possible worldwide credit card transactions, telephone and utility service billing, government services, and banking ATM networks. And while some computing services traditionally hosted at an EDC are being migrated to distributed computing platforms online, usually for reasons of cost, EDCs continue to be used extensively worldwide.

Computer technology, business priorities, and trends in the data-center industry change over time, and EDC owners must respond to them. For many data center owners, a building's aging infrastructure—primarily

HVAC, power, and security systems—is a major problem because it may not support current or future business requirements, which can include better energy efficiency, the ability to easily reconfigure floor space and support changing electrical loads, and comprehensive monitoring and control of the facility.

This was the situation at a long-established EDC in Phoenix, Arizona, the property of a global company that provides data processing and payment services, including retail transactions and an ATM network, to millions of people worldwide.

Over time, the company's 30 year-old EDC had become increasingly inefficient for operating in the hot desert climate, and its HVAC and mechanical systems needed to be upgraded. Another problem was that the raised floor space couldn't easily be reconfigured as new computer systems were brought in and older systems relocated or removed.

The Solution

Phoenix-based Arizona Facility Services (AFS) was brought in to retrofit the data center. AFS specializes in critical facility infrastructure and has built or retrofitted data centers across the United States. The company's



Carlos Terrazas (left) and Drazen Baricevic (right) with Arizona Facility Services (AFS) in the chiller plant of a retrofitted data center.

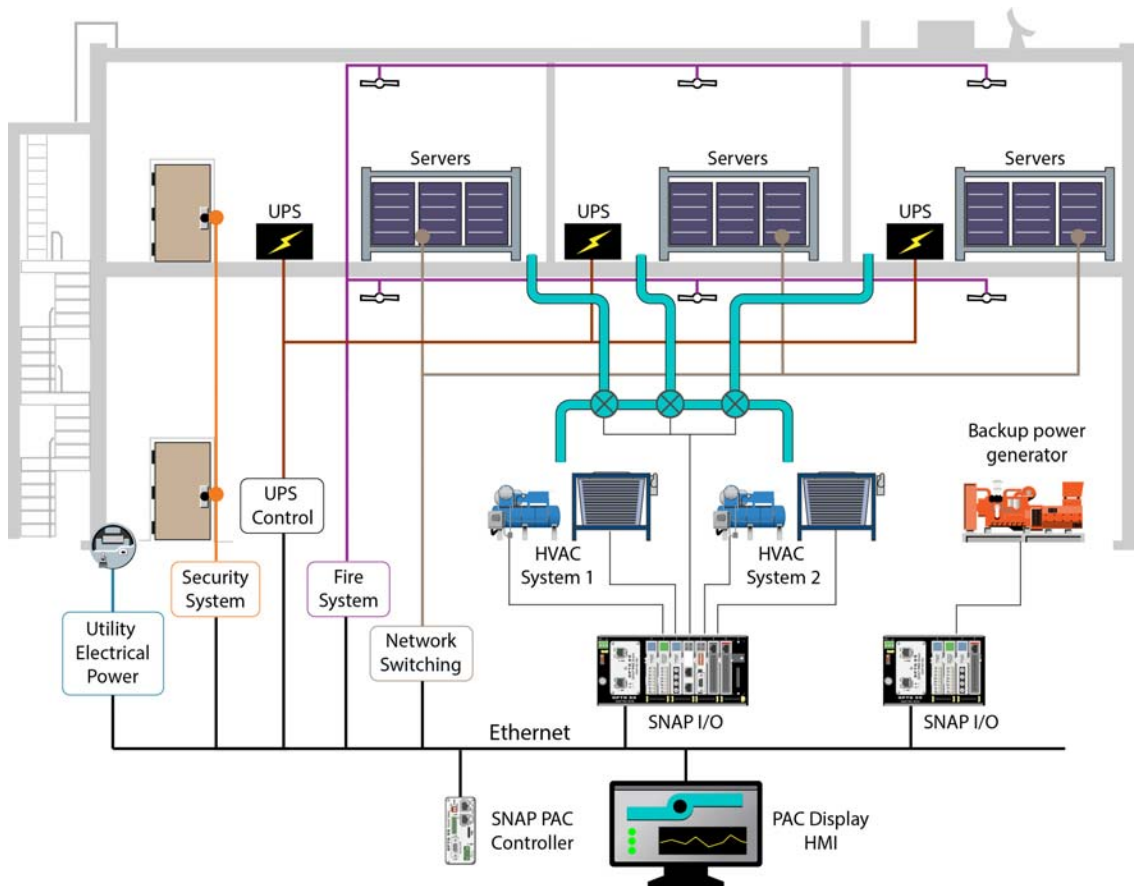

Power, security, fire, and other critical infrastructure systems in the data center were integrated into the new BAS.

primary focus is HVAC, mechanical, and power systems, and most AFS staff has hands-on experience working at data centers. This positions the company well to meet a demand for data center infrastructure management (DCIM), the industry term for integrated, facility-wide monitoring and control of all building systems and equipment.

AFS President Drazen Baricevic describes the retrofit at the Phoenix data center as comprehensive. "In addition to facilitating installation of new systems, we integrated existing equipment and systems throughout the facility," says Baricevic.

"This includes emergency power systems," he continues, "namely generators and UPS battery backup systems, as well as the building's central cooling system, which has a number of independently operated chillers. This was all integrated into a building automation system (BAS) that

provides detailed, facility-wide monitoring and precise equipment control."

"The facility had used a Johnson Controls BAS for over 15 years," says Baricevic, "but the existing system's service was unsatisfactory, and would have required costly upgrades to meet the data center's growing service needs and future BAS requirements."

He adds that the Johnson Controls BAS required expensive periodic system updates of both software and hardware, so cost became a factor when projecting how the data center would evolve over time. "Plus," Baricevic continues, "we were looking for more 'open' systems that supported communication protocols for many different building automation, power, and other systems."

AFS discovered the Opto 22 SNAP PAC System and was pleased to find that the control system had no annual licensing or periodic update requirements, and included broad communications support for BACnet/TCP, Modbus,

and EtherNet/IP protocols as well as many other devices and systems. They found another benefit in the wide range of input/output (I/O) modules available to support analog, digital, and serial signals.

When complete, the retrofit included Opto 22 programmable automation controllers (PACs) and SNAP I/O connected over Ethernet networks. Using Opto 22's PAC Project suite of automation software, AFS Developer Martin Baricevic programmed controllers and built modern operator interfaces and displays.

All data centers share priorities of *reliable operation* to provide maximum uptime for computer systems, *facility security*, and *energy efficiency*, and the AFS retrofit fully addressed each of them. Highly redundant control systems, not commonly found in building automation systems, are often needed to meet these priorities.

For this, AFS leveraged the flexibility of the SNAP PAC System to design *unlimited dynamic redundancy*, an innovative configuration of control system components running on dual Ethernet networks that provides maximum control system redundancy. Redundant operation includes the HVAC ductwork, which has a cross-zone configuration; if a cooling zone in the data center fails, that zone can be isolated and then supplied by a duct from an adjacent zone.

Results

The data center retrofit resulted in a modern enterprise data center with a highly integrated building automation system. Improved infrastructure oversight allowed systems and equipment to be operated more efficiently, resulting in a reduction in energy use of over 20% for many systems.

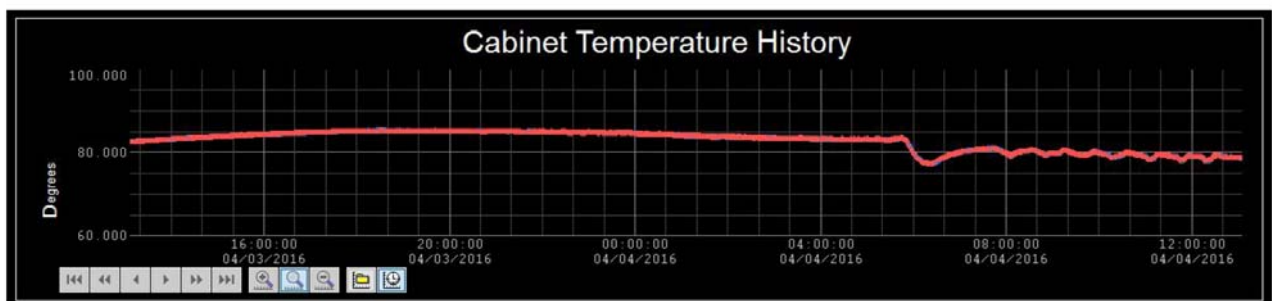
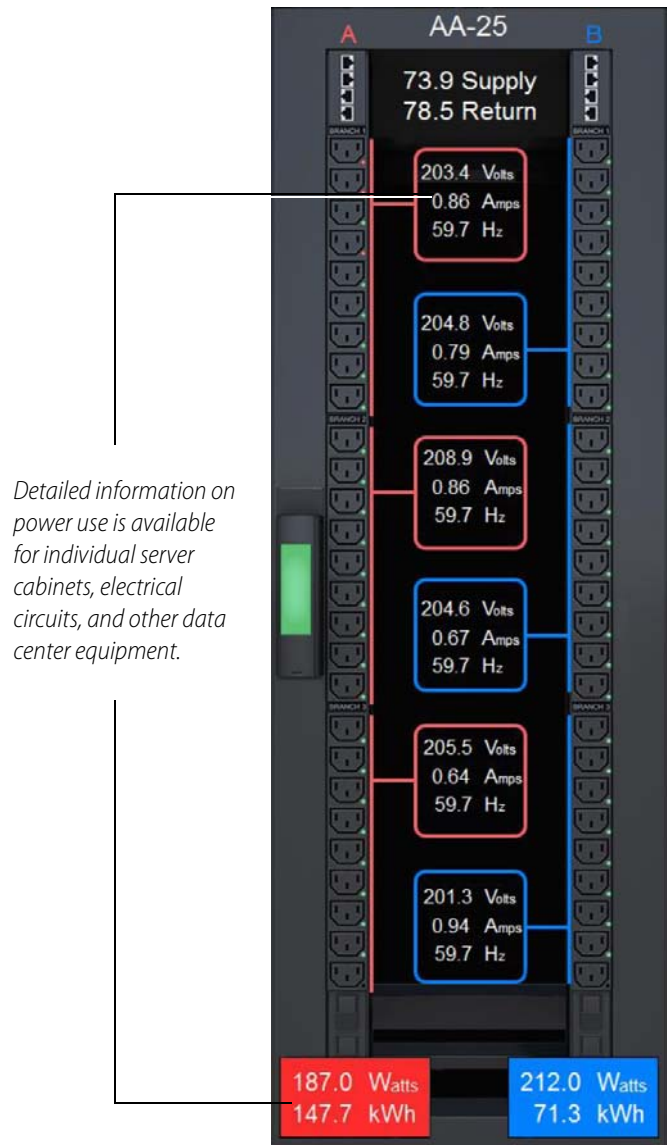

Temperature and energy demand data for individual server cabinets is logged and subsequently analyzed for predictive maintenance.



Martin Baricevic at AFS developed control programs and built operator interfaces and displays using PAC Project software from Opto 22.

Data collection and system monitoring is now much more comprehensive and lets the owner optimize facility systems when new computer equipment is added or existing equipment relocated within the facility. In addition this newly available data makes preventative and predictive maintenance possible, which results in greater facility reliability and cost savings.

About Arizona Facility Services (AFS)

Arizona Facility Services (AFS) provides an extensive range of services and support for mission-critical data centers, including architectural planning, construction, facility commissioning, and infrastructure maintenance after the facility is operational. AFS takes pride in creating innovative building automation and controls solutions that are tailored to the customer's business needs, and has worked

with major corporations across North America. By delivering solutions that integrate diverse electrical and mechanical systems into a comprehensive, facility-wide system for data center infrastructure management, AFS remains true to its motto of building better relationships—one customer at a time. www.azfacility.com

About Opto 22

Opto 22 develops and manufactures hardware and software for applications involving industrial automation and control, energy management, remote monitoring, and data acquisition.

Designed and made in the U.S.A., Opto 22 products have an established reputation worldwide for ease-of-use, innovation, quality, and reliability. Opto 22 products, including the *groov* mobile operator interface, use standard, commercially available networking and computer technologies, and are used by automation end-users, OEMs, and information technology and operations personnel in over 10,000 installations worldwide. The company was founded in 1974 and is privately held in Temecula, California, U.S.A. Opto 22 products are available through a global network of distributors and system integrators. For more information, contact Opto 22 headquarters at +1-951-695-3000 or visit www.opto22.com.

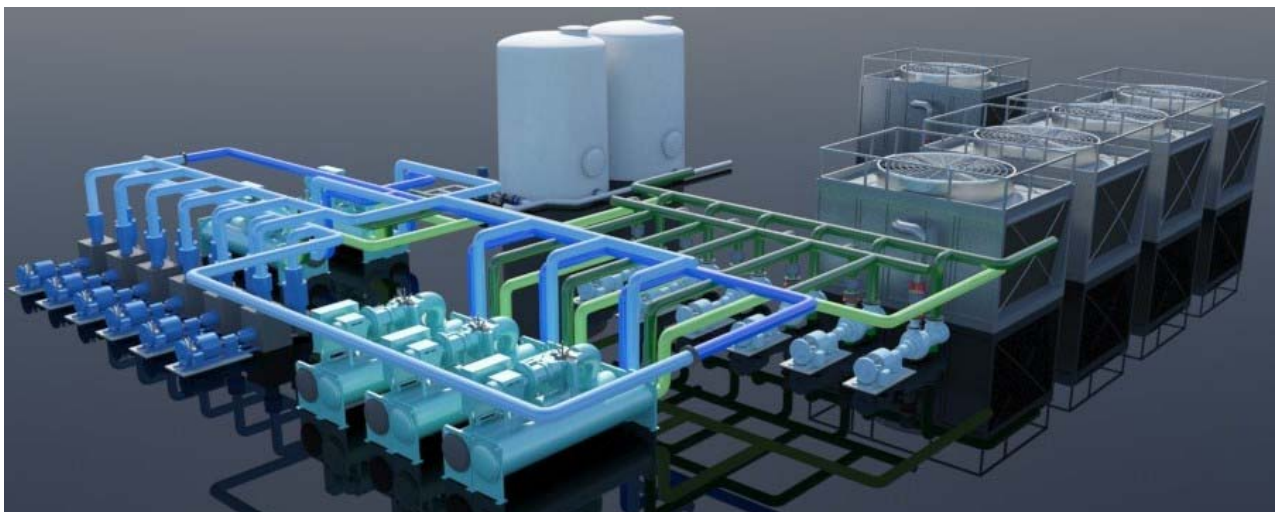

Individual cooling system chillers, pumps, and tanks are integrated into the data center's new BAS.