

OPTO 22 ENERGY MONITORING UNIT QUICK START GUIDE

Form 1816-100309—March 2010

OPTO 22

43044 Business Park Drive • Temecula • CA 92590-3614

Phone: 800-321-OPTO (6786) or 951-695-3000

Fax: 800-832-OPTO (6786) or 951-695-2712

www.opto22.com

Product Support Services

800-TEK-OPTO (835-6786) or 951-695-3080

Fax: 951-695-3017

Email: support@opto22.com

Web: support.opto22.com

Opto 22 Energy Monitoring Unit Quick Start Guide
Form 1816-100309—March 2010

Copyright © 2010 Opto 22.

All rights reserved.

Printed in the United States of America.

The information in this manual has been checked carefully and is believed to be accurate; however, Opto 22 assumes no responsibility for possible inaccuracies or omissions. Specifications are subject to change without notice.

Opto 22 warrants all of its products to be free from defects in material or workmanship for 30 months from the manufacturing date code. This warranty is limited to the original cost of the unit only and does not cover installation, labor, or any other contingent costs. Opto 22 I/O modules and solid-state relays with date codes of 1/96 or later are guaranteed for life. This lifetime warranty excludes reed relay, SNAP serial communication modules, SNAP PID modules, and modules that contain mechanical contacts or switches. Opto 22 does not warrant any product, components, or parts not manufactured by Opto 22; for these items, the warranty from the original manufacturer applies. These products include, but are not limited to, OptoTerminal-G70, OptoTerminal-G75, and Sony Ericsson GT-48; see the product data sheet for specific warranty information. Refer to Opto 22 form number 1042 for complete warranty information.

Wired+Wireless controllers and brains and N-TRON wireless access points are licensed under one or more of the following patents: U.S. Patent No(s). 5282222, RE37802, 6963617; Canadian Patent No. 2064975; European Patent No. 1142245; French Patent No. 1142245; British Patent No. 1142245; Japanese Patent No. 2002535925A; German Patent No. 60011224.

Opto 22 FactoryFloor, Optomux, and Pamux are registered trademarks of Opto 22. Generation 4, ioControl, ioDisplay, ioManager, ioProject, ioUtilities, *mistic*, Nvio, Nvio.net Web Portal, OptoConnect, OptoControl, OptoDataLink, OptoDisplay, OptoOPCServer, OptoScript, OptoServer, OptoTerminal, OptoUtilities, PAC Control, PAC Display, PAC Manager, PAC Project, SNAP Ethernet I/O, SNAP I/O, SNAP OEM I/O, SNAP PAC System, SNAP Simple I/O, SNAP Ultimate I/O, and Wired+Wireless are trademarks of Opto 22.

ActiveX, JScript, Microsoft, MS-DOS, VBScript, Visual Basic, Visual C++, Windows, and Windows Vista are either registered trademarks or trademarks of Microsoft Corporation in the United States and other countries. Linux is a registered trademark of Linus Torvalds. Unicenter is a registered trademark of Computer Associates International, Inc. ARCNET is a registered trademark of Datapoint Corporation. Modbus is a registered trademark of Schneider Electric. Wiegand is a registered trademark of Sensor Engineering Corporation. Nokia, Nokia M2M Platform, Nokia M2M Gateway Software, and Nokia 31 GSM Connectivity Terminal are trademarks or registered trademarks of Nokia Corporation. Sony is a trademark of Sony Corporation. Ericsson is a trademark of Telefonaktiebolaget LM Ericsson. CompactLogix and RSLogix are trademarks of Rockwell Automation. Allen-Bradley and ControlLogix are registered trademarks of Rockwell Automation. CIP and EtherNet/IP are trademarks of ODVA.

All other brand or product names are trademarks or registered trademarks of their respective companies or organizations.

Table of Contents

Chapter 1: Installing the OptoEMU1	1
Introduction	1
For Help	1
Installing the Unit	2
What You Will Need	2
Attaching the Unit to the Wall	2
Wiring the Module	3
Three-Phase Wiring to SNAP-AIPM-3 Module	4
Applying Power to the Unit	5
Finishing Installation	5
Configuring the Unit	5
Installing Software	5
Assigning an IP Address to the OptoEMU1	6
Configuring the Controller	9
Scaling Points on the SNAP-AIPM-3	10
Scaling Example 1	11
Scaling Example 2	11
Scaling Example 3*	12
Downloading the Strategy to the Controller	13
Launching the Sample HMI	14
Setting Graphic Scales	15
Dimensional Drawings	18
Specifications	19
Chapter 2: Monitoring Devices	21
Using the Main Window	21

Viewing Current Energy Usage	22
Viewing Historical kWh Data	23
Viewing Historical Energy Data	25
Using Alarms and Email Notification	27
Setting Up Alarms	27
Viewing and Acknowledging Alarms	28
Defining Expected Energy Use and Email Notification	28
What's Next?	30

1: Installing the OptoEMU1

Introduction

This guide shows you how to install and use an Opto 22 Energy Monitoring Unit (OptoEMU1), part number SNAP-IT-EMU1.

The OptoEMU1 lets you monitor energy usage for a three-phase electrical device—for example, air conditioning and heating unit, compressor, or electric motor—so you can anticipate energy bills and respond quickly when energy use rises unexpectedly.

The unit includes a sample monitoring program and an HMI, both of which you can modify or use as an example for your own application. Complete software and documentation are included.

Hardware is also expandable. If you need to monitor additional devices or to control devices, you can add more I/O modules to the rack. For information about available modules, visit our website (www.opto22.com) or contact Pre-sales Engineering (phone 800-321-6786 or email systemseng@opto22.com).

For Help

If you have trouble installing or using the OptoEMU1 and cannot find the help you need in this guide or on our website (www.opto22.com), please contact Opto 22 Product Support.

Phone:	800-TEK-OPTO (835-6786) 951-695-3080 (Hours are Monday through Friday, 7 a.m. to 5 p.m. Pacific Time)
Fax:	951-695-3017
Email:	support@opto22.com
Opto 22 website:	www.opto22.com

NOTE: Email messages and phone calls to Opto 22 Product Support are grouped together and answered in the order received.

Installing the Unit

The OptoEMU1 includes the following hardware, pre-wired in a sturdy polycarbonate industrial enclosure:

- SNAP-PAC-R2 programmable automation controller
- SNAP-AIPM-3 analog input module
- Power supply
- Mounting rack (with three unused slots for expansion)

What You Will Need

You'll need the following items to install the OptoEMU1 unit:

- OptoEMU1 unit (provided)
- 100–240 VAC power on a dedicated circuit breaker
- Wire and fuses as required by the wiring diagram you are using (see [page 4](#))
- Current transformers appropriate for the device you are monitoring
- Category 5 or better solid UTP cable with RJ-45 connector to a 10/100 Mbps Ethernet network
- Four #8 screws for attaching the unit to the wall (Screw type depends on wall material and construction.)
- Standard screwdrivers (large and small). Depending on the installation, additional tools may be needed.

NOTE: The OptoEMU1 can monitor devices using 85–250 volts and 0–10 amps, and it can also monitor AC line currents greater than 10 amps using a standard current transformer (CT) of suitable ratio. For line voltage higher than 250 VAC, use a step-down potential transformer. If hazardous voltage or current is to be monitored, an interposing potential transformer and a CT must be used for safety.

Attaching the Unit to the Wall

1. Remove the OptoEMU1 unit from its packaging.

NOTE: Dimensional drawings are on [page 18](#).

2. Using a standard screwdriver, unscrew the four screws in the unit's cover and take off the cover. Save the screws.
3. Notice the parts of the unit, shown below. The SNAP PAC controller and the I/O module are mounted on the rack. The AC power inlet is at the bottom of the unit. Mounting holes are located at each corner.

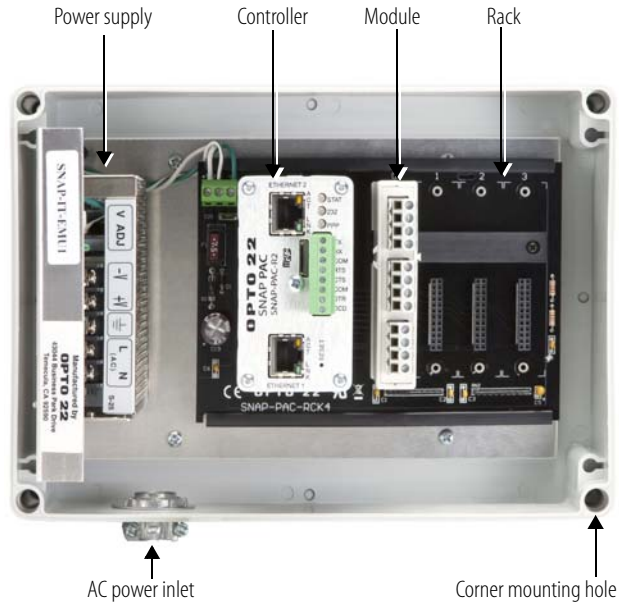

4. Find a wall location that's convenient for monitoring the device. Make sure there is space on at least two sides for ventilation (preferably top and bottom).
5. Using four #8 screws suitable for the wall's construction, mount the unit to the wall through the same corner holes used to attach the cover. (See dimensional drawings on [page 18](#).)

An alternative method is to unscrew the hardware panel from the box and use the secondary mounting holes at the back of the box to attach the unit to the wall; then replace the panel.

Wiring the Module

As the diagram shows, the OptoEMU1 unit contains one SNAP I/O module, a SNAP-AIPM-3.

1. Remove a convenient knockout. Run the wires from the device being monitored, through the knockout hole, and into the unit. Use a strain-relief connector if needed.
2. Wire the module to the device using the diagram on the following page.

Three-Phase Wiring to SNAP-AIPM-3 Module

CAUTION: Be very careful when connecting input channels. **Do not connect line voltage to the current input channel;** such a connection will cause **severe damage** to the module. This damage is **not covered by warranty**. Use a current transformer instead.

CAUTION: Use caution when selecting wire gauges for your application. Use conservative wire gauges with proper voltage ratings.

CAUTION: Terminals 2 and 3 share a common connection inside the module. **Make sure you observe polarity** when connecting the second channel. To avoid a potentially hazardous short circuit, double-check wiring before turning on the current to be monitored.

WARNING! Disconnect power upstream from unit when wiring or servicing to avoid potential shock hazard. This unit must be on its own circuit breaker.

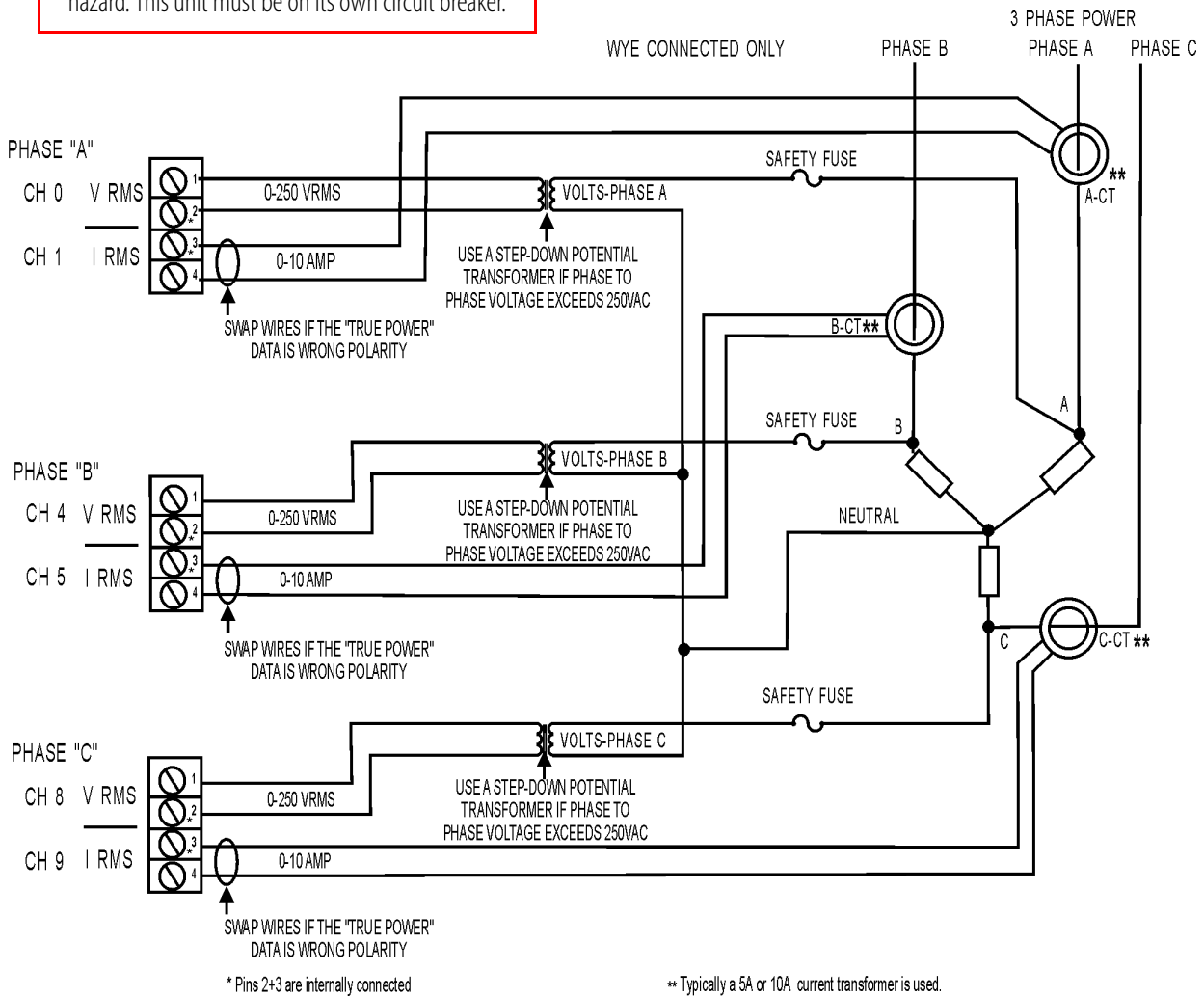

CAUTION: The SNAP-AIPM-3 module does not contain a fuse. Protect the system by adding a fuse.

Suggested vendors

Protection fuses: <http://www.littelfuse.com>

Voltage and current transformers: <http://www.crmagnetics.com>

Applying Power to the Unit

WARNING: Install the unit on a dedicated circuit breaker so power can be turned off for maintenance. The unit itself does not have a power switch.

1. Run 100–240 VAC power from a dedicated circuit breaker through the AC power inlet and wire it to the power supply.
2. If necessary, provide strain relief for the power cord.

Finishing Installation

1. If the OptoEMU1 unit is mounted in an area with high air temperature, provide ventilation for the unit by removing four unused knockouts on the box, preferably two at the bottom and two at the top. Place a black nylon vented finishing plug (provided) in each hole.
2. Plug a standard Category 5 or better solid UTP cable with an RJ-45 connector into the *Ethernet 1* network interface on the controller. Connect the cable to the 10/100 Mbps Ethernet network that will be used for monitoring.
3. Notice the white label on the side of the controller. Write down the MAC address (MAC 1 only), as you will need it later to assign the unit an IP address. After you assign the IP address, you will write it on this label for future reference.

Configuring the Unit

Installing Software

Software requirements:

- Computer with at least the minimum processor required for your version of Microsoft® Windows® (single or dual core, 1 GHz Pentium®-class or better recommended) and Ethernet capability, on the same subnet as the OptoEMU1.
 - Windows Vista® Business (32-bit), Windows XP Professional (with SP2 or higher) or Windows 2000® (with SP4) workstation operating system. Microsoft Windows server, 64-bit versions of Windows workstation, and embedded operating systems are not supported.
 - At least 1 GB RAM for Windows Vista, or at least 512 MB for Windows XP or Windows 2000.
 - VGA or higher resolution monitor (Super VGA recommended), minimum size 1024 x 768.
 - Mouse or other pointing device. Printer optional.
 - Available hard disk space required: 124 MB
1. If PAC Project is not yet installed on a PC on the same network segment as the OptoEMU1, put the PAC Project Software Suite CD into the CD-ROM drive. Installation should begin automatically. If it does not, navigate to the CD and double-click Setup.exe to begin.

2. When PAC Project is installed, remove its CD from the CD-ROM drive and insert the OptoEMU1 Samples CD. Again, installation should begin automatically, or you can navigate to the CD and double-click Setup.exe to begin.

PAC Project Basic software and the sample control and HMI programs are now installed. You can configure the OptoEMU1, use the HMI, and modify the sample programs for your application.

Default file locations:

- PAC Project Software Suite: Programs/Opto 22/PAC Project/
- OptoEMU1 sample files: Programs/Opto 22/OptoEMU1/

Assigning an IP Address to the OptoEMU1

When you first turn on the OptoEMU1, it sends out a BootP broadcast requesting an IP address. You must assign the OptoEMU1 a **unique, fixed IP address** so you can communicate with it on your network. Work with your network administrator to determine the IP address and subnet mask to use.

If the network you're using has a Dynamic Host Configuration Protocol (DHCP) server, either assign a static IP address before connecting the OptoEMU1 to the network (preferred), or disable the server. (If you don't, the DHCP server may respond to the BootP request and assign a dynamic address.)

NOTE: To make sure the controller or I/O unit is not on a network with a DHCP server, we recommend you use a crossover cable with a direct connection. If you connect directly to a PC that is normally on a DHCP network, you must assign a fixed IP address to the PC's network card (NIC) in order to communicate.

Also, since BootP broadcasts cannot get through a firewall in the PC, disable any firewall (such as the built-in firewall in Windows XP). Firewalls in a router should not be a problem.

1. Have handy the OptoEMU1's MAC 1 address, which you wrote down from the label on the side of the controller.
2. On the PC's Start menu, choose Programs > Opto 22 > PAC Project > PAC Manager.

The PAC Manager main window opens.

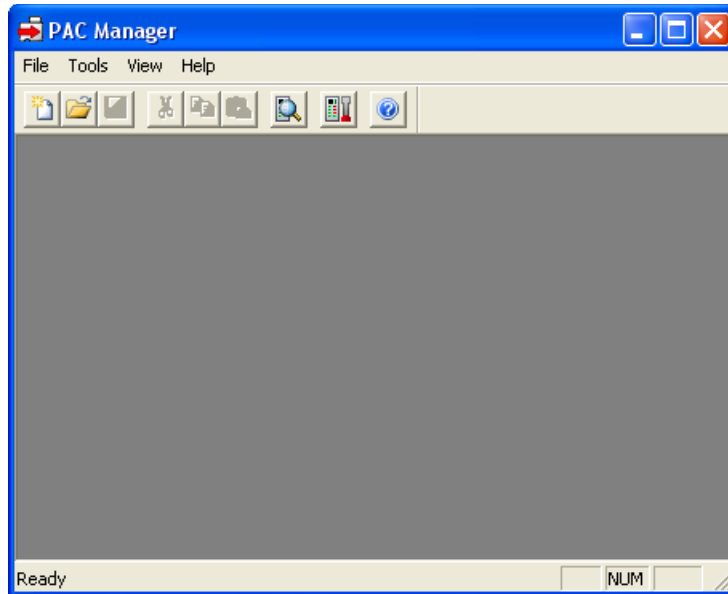

3. From the Tools menu, choose Assign IP Address.
4. Apply power to the OptoEMU1 by switching its circuit breaker to ON.

The following dialog box opens on the PC. Any Opto 22 Ethernet-based devices without IP addresses that are on the PC's network segment appear in the list of units requesting IP addresses.

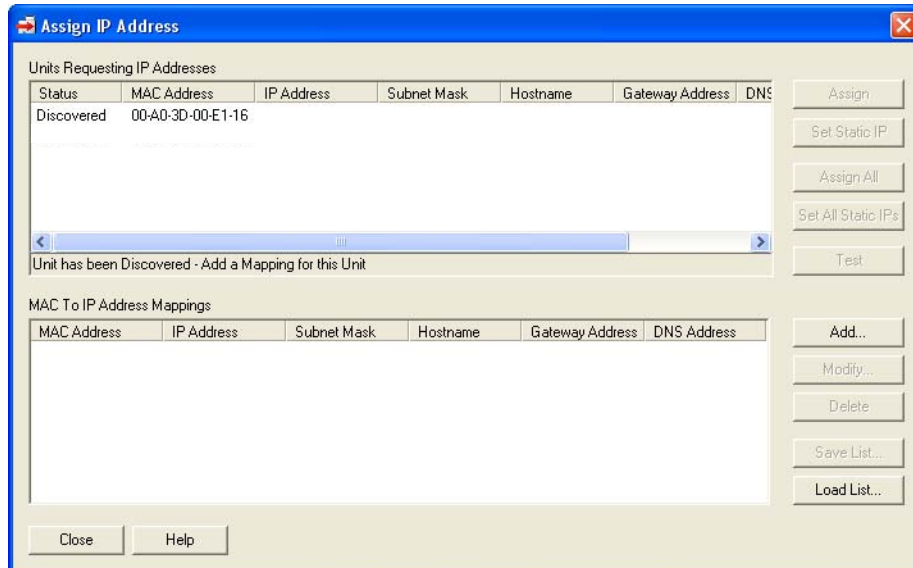

- In the list, double-click the MAC 1 address of the OptoEMU1.

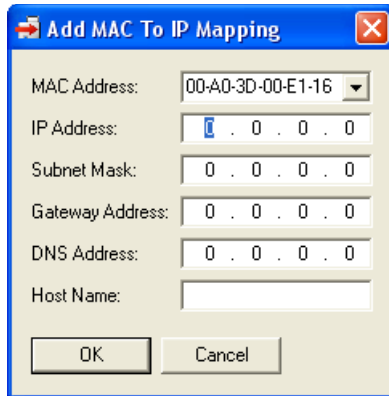

- Enter the IP Address and the Subnet Mask for the device. If it will be talking to a device on another subnet, enter the Gateway (router) address. If it will talk only on the local subnet, leave the gateway address all zeros (0.0.0.0). Leave the DNS address at 0.0.0.0 and the Host Name field blank.

CAUTION: Each device on your network, including computers, routers, controllers, brains, and so on, must have a unique IP address. Failure to assign unique IP addresses may cause catastrophic network or hardware failures. If you don't know which IP addresses are safe to use, check with your system administrator.

- When all fields are correct, click OK.

The new IP address information appears in the upper list in the dialog box, and the device's status changes to Mapped. The address information also appears in the lower list.

- With the device still highlighted, click Assign.

The address is saved to flash memory, and the status changes to Static IP.

- To verify that the IP address has been successfully assigned, highlight the device in the upper list and click Test.

A DOS window opens and the IP address is automatically contacted using the PING program. You should see a reply similar to the following:

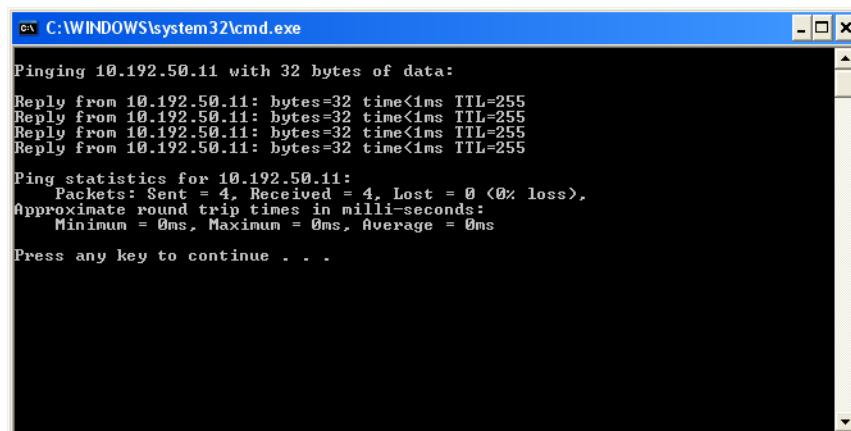

If you don't see a reply, make sure the subnet mask you've assigned matches the subnet mask on your PC.

10. For future reference, write the IP address next to the MAC address on the white sticker inside the OptoEMU1.
11. Using the OptoEMU1's original four corner screws, replace the unit's cover.
12. On the PC, close PAC Manager.

Configuring the Controller

1. Open Windows Explorer and navigate to C:\Program Files\Opto 22\OptoEMU1\Power Monitor Strategy. Double-click `Power Monitor Strategy.idb` to open the control program (called a *strategy*).

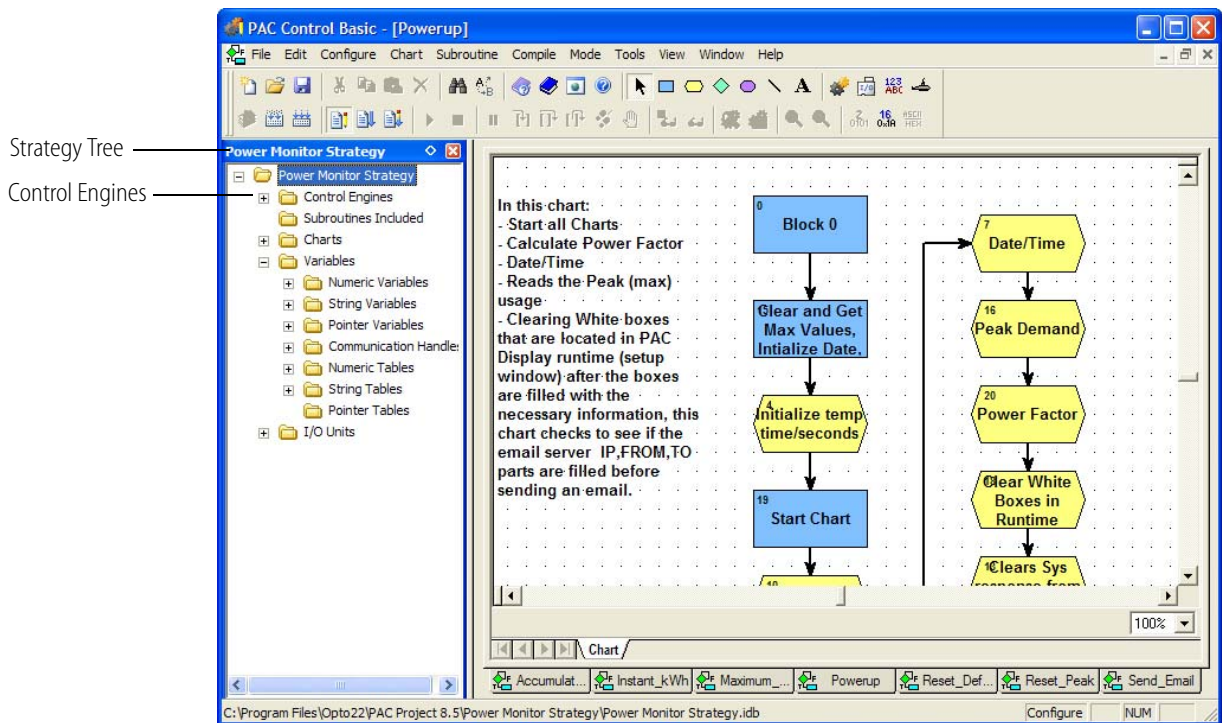

2. In the Strategy Tree, double-click the Control Engines folder. Click Add twice to get to the Control Engine Configuration dialog box shown below:

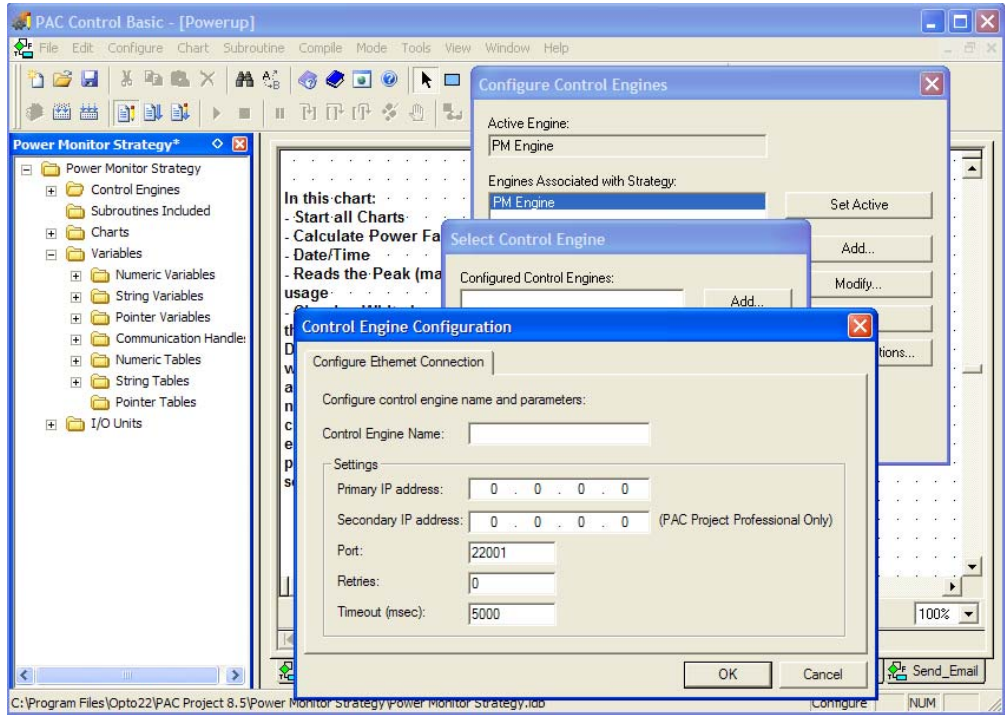

3. In the Control Engine Name field, type: `PM Engine`
4. In the Primary IP address field, type the IP address you just assigned to the OptoEMU1. Leave the other Settings as they are. Click OK.
5. Make sure that PM Engine is highlighted and click OK again (twice) to return to the main window.

Scaling Points on the SNAP-AIPM-3

To make sure values appear correctly in the HMI, you must alter the scale for points on the SNAP-AIPM-3 module to match the inputs and ratio of the current transformer (CT) you use. The examples below will help you determine the correct values for your CT; then follow the steps on [page 12](#) to enter them.

Important: For *all* installations of 85 to 250 VAC, both Actual and Scaled Volts remain at 0–250 VAC. For installations over 250 VAC (such as lighting systems using 277 volts), you will need to scale volts, however. See “[Scaling Example 3*](#)” on [page 12](#).

Scaling Example 1

CT primary	CT sec	CT ratio
250	5	50

Points 0, 4, 8		
	Actual	Scaled
Unit	VAC/VDC	VAC/VDC
Lower	0	0
Upper	250	250

Points 1, 5, 9		
	Actual	Scaled
Unit	A	A
Lower	0	0
Upper	5	250

Points 2, 6, 10		
	Actual	Scaled
Unit	W	W
Lower	0	0
Upper	2500	125000

Points 3, 7, 11		
	Actual	Scaled
Unit	VA	VA
Lower	0	0
Upper	2500	125000

Points 12 & 13		
	Actual	Scaled
Unit	J	J
Lower	0	0
Upper	7500	375000

Scaling Example 2

CT primary	CT sec	CT ratio
50	5	10

Points 0, 4, 8		
	Actual	Scaled
Unit	VAC/VDC	VAC/VDC
Lower	0	0
Upper	250	250

Points 1, 5, 9		
	Actual	Scaled
Unit	A	A
Lower	0	0
Upper	5	50

Points 2, 6, 10		
	Actual	Scaled
Unit	W	W
Lower	0	0
Upper	2500	25000

Points 3, 7, 11		
	Actual	Scaled
Unit	VA	VA
Lower	0	0
Upper	2500	25000

Points 12 & 13		
	Actual	Scaled
Unit	J	J
Lower	0	0
Upper	7500	75000

Scaling Example 3*

CT primary	CT sec	CT ratio
400	10	40

	Points 0, 4, 8	
	Actual	Scaled
Unit	VAC/VDC	VAC/VDC
Lower	0	0
Upper	138.5	277

	Points 1, 5, 9	
	Actual	Scaled
Unit	A	A
Lower	0	0
Upper	10	400

	Points 2, 6, 10	
	Actual	Scaled
Unit	W	W
Lower	0	0
Upper	2500	100000

	Points 3, 7, 11	
	Actual	Scaled
Unit	VA	VA
Lower	0	0
Upper	2500	100000

	Points 12 & 13	
	Actual	Scaled
Unit	J	J
Lower	0	0
Upper	7500	300000

** Note that this example of line voltage higher than 250 VAC requires the use of a step-down potential transformer.*

If hazardous voltage or current is to be monitored, an interposing potential transformer and a CT must be used for safety.

1. In the Strategy Tree, click the plus sign next to the I/O Units folder to open it. Also click the plus signs next to PM_Module and Points.

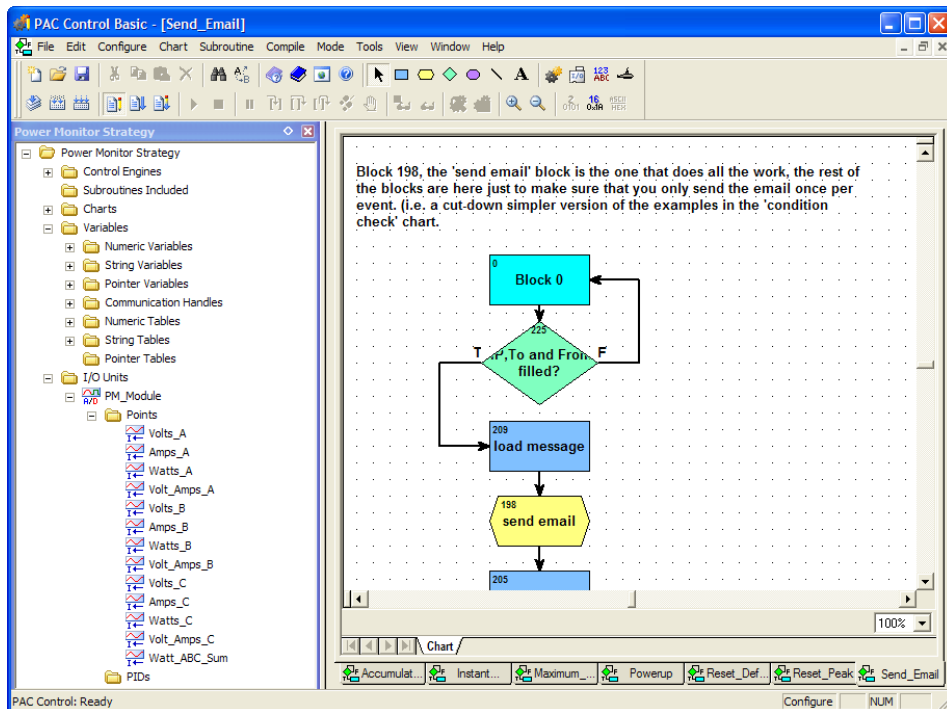

2. Double-click Amps_A to open the Edit Analog Point dialog box.

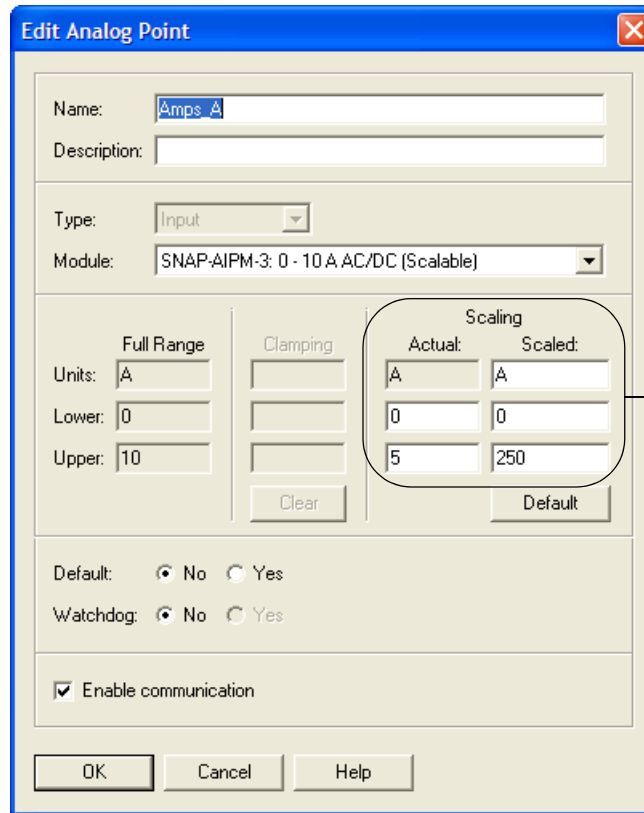

Enter actual and scaled values here.

3. In the Scaling area, enter the correct Actual and Scaled values for your CT.
For “Scaling Example 1” on page 11, you would enter 5 for Actual Upper and 250 for Scaled Upper.
4. Click OK.
5. Repeat step 2 through step 4 for all the points that need scaling. (For Example 1, that would be all points *except* Volts A, B, and C. The last two points are True Power in joules).

Downloading the Strategy to the Controller

1. From the Mode menu, choose Debug to download the strategy to the OptoEMU1. Click Yes or OK in response to all messages.

The strategy is loaded and saved to flash memory. In case of power loss, the strategy will automatically start running again when power is restored.

2. Once the strategy is downloaded, choose Debug > Run or click the Run button .

The control strategy begins running on the OptoEMU1. Since it runs independently from the PC, you can close PAC Control. Or, if you want to see how the strategy works, you can leave it open and look at the flowcharts and elements in the Strategy Tree.

The PAC Control Basic software installed on your PC is a fully operational version that you can use to modify or expand the control strategy to fit your application. The *PAC Control User's Guide*

and the *PAC Control Command Reference* give you complete documentation; choose Start > Programs > Opto 22 > PAC Project > Manuals to open the PDFs.

Launching the Sample HMI

1. In Windows Explorer, navigate to C:\Program Files\Opto 22\OptoEMU1\Power Monitor Display. Double-click `Power Monitor Display xp.usi` to open the HMI program.

The file opens in PAC Display Configurator, which is the development application; later you will use it in PAC Display Runtime, which is the operator interface application.

2. At the message saying it can't find the strategy file, click OK.

The Control Engines dialog box opens:

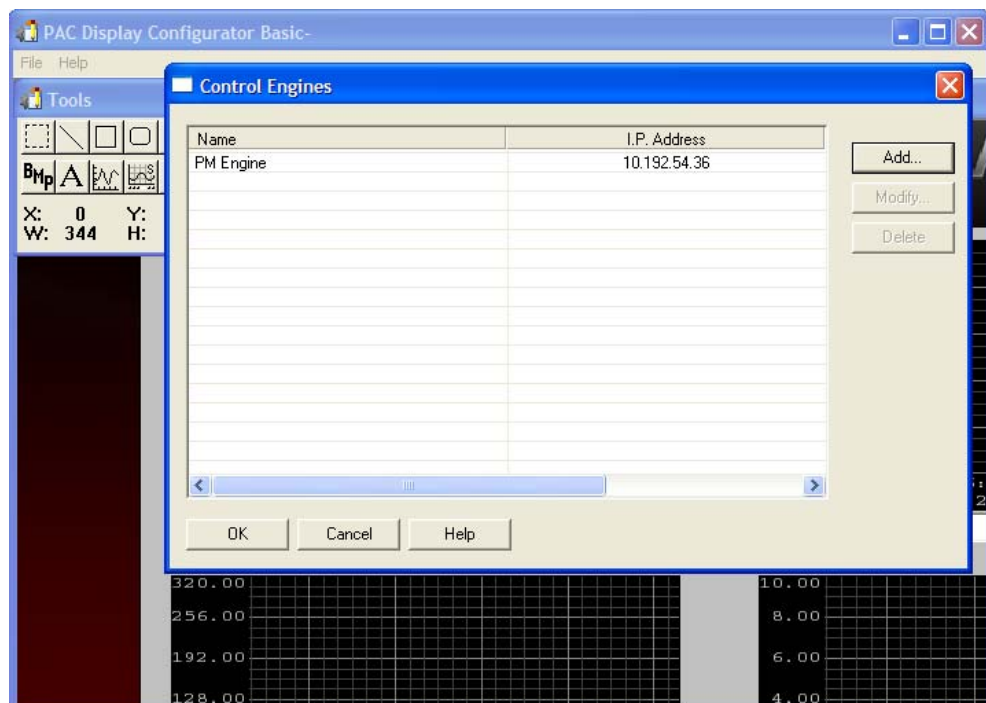

3. Highlight PM Engine and click Modify.

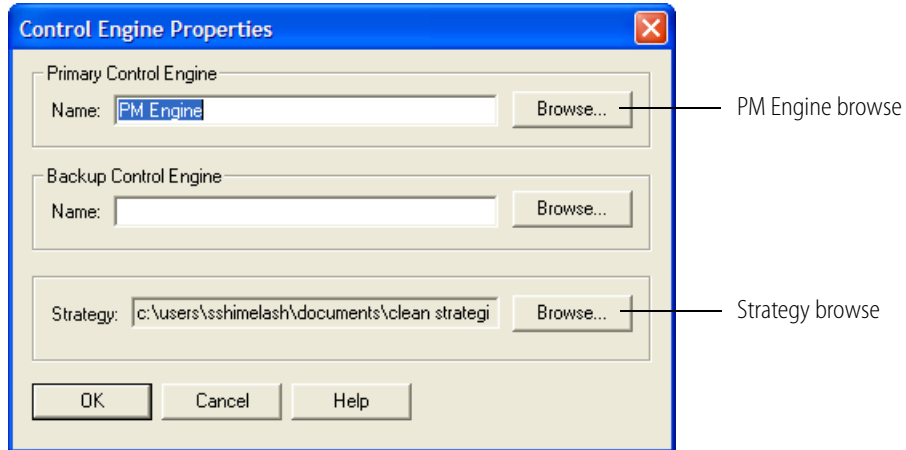

4. Click the Browse button next to PM Engine. In the Select Control Engine dialog box, highlight PM Engine and click OK.
5. Click the Browse button next to Strategy. If you see a message about tags becoming invalid, click Yes to continue. Navigate to C:\Program Files\Opto 22\OptoEMU1\Power Monitor Strategy\Power Monitor Strategy.idb and open this strategy file. Click OK twice to return to the PAC Display main window.

Setting Graphic Scales

Just as you set scaling for the points in the strategy, now you need to change the scale of the HMI graphics to match your configuration. You're in the PAC Display Configurator main window:

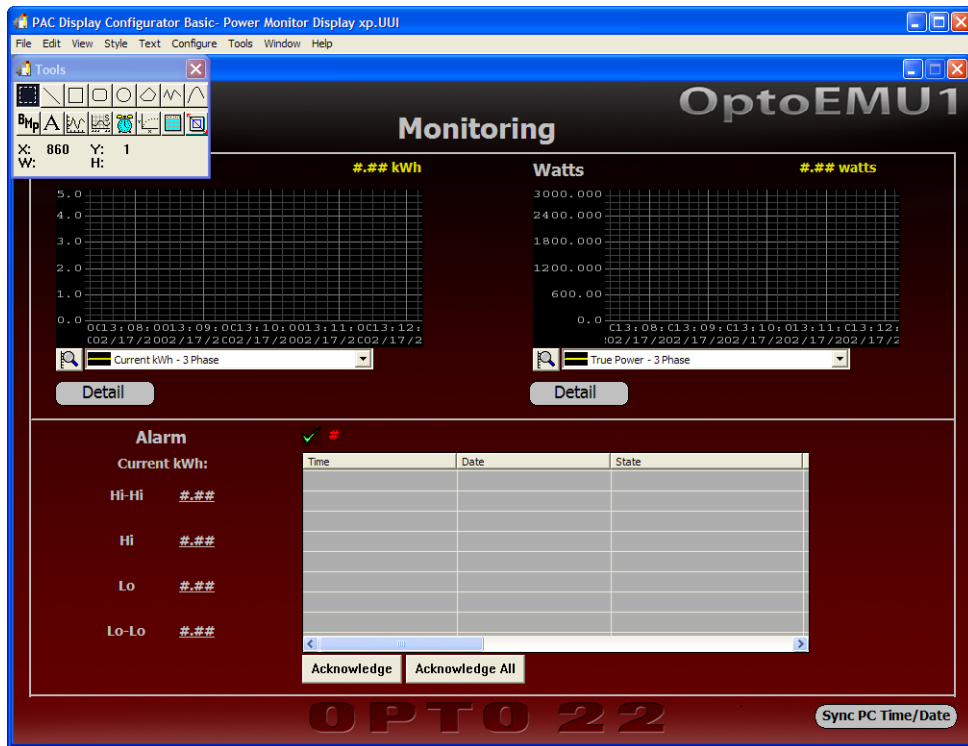

1. Double-click in the center of the graph at the upper left (the one that says kWh in yellow).

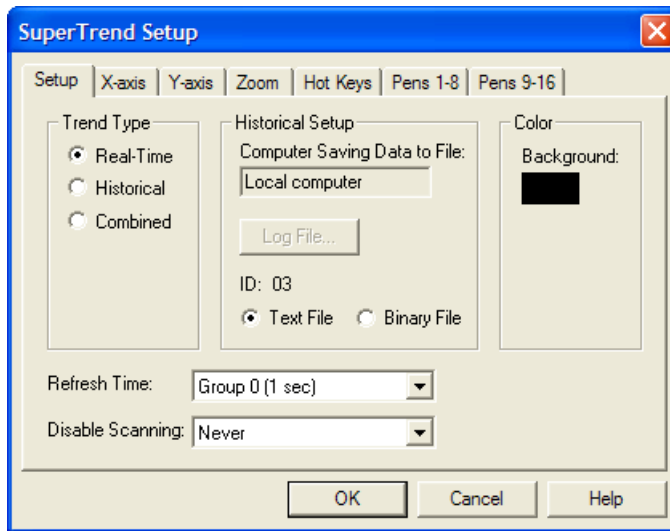

2. Click the Pens 1-8 tab.

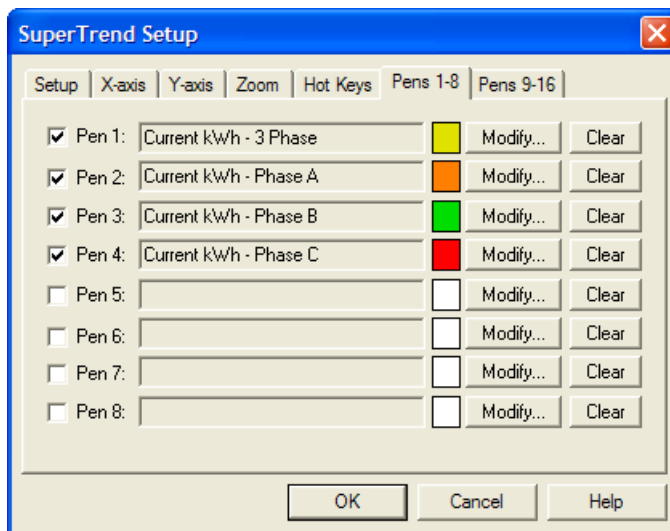

3. Next to the first pen (3Phase, the yellow one), click the Modify button.

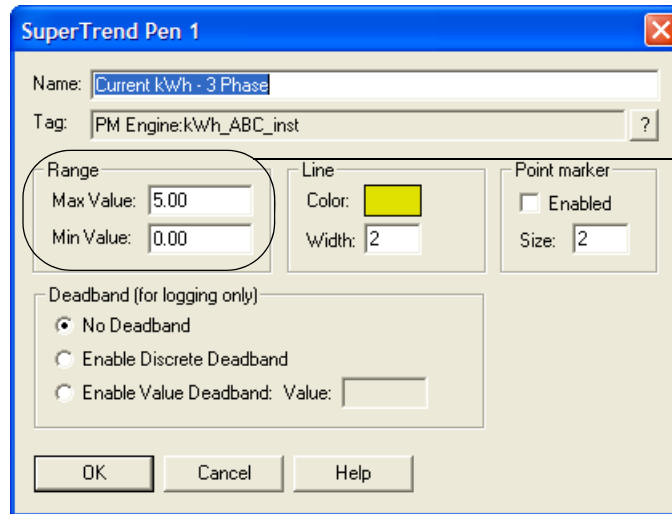

Change values here to match points in PAC Control.

4. In the Range area, enter the same scaled values you entered for this point in PAC Control. Then click OK.
5. Repeat step 4 for the other three pens shown. Then click OK to go back to the main window. If a message asks if you want to keep these settings, click Yes.
6. Back in the Monitoring window, double-click the Watts graph and repeat steps 2 through 5. You've now scaled the Monitoring window graphs. The other two windows also need to be scaled.
7. In the Monitoring window, choose Window > Power to open the Energy Detail window. Double-click each of the three graphs in this window and repeat steps 2 through 6.
8. When you've finished the Energy Detail (Power) window, choose Window > kWh to open the kWh Detail window. Again, double-click each graph and repeat steps 2 through 6. All HMI graphs should now match your application.
9. Choose File > Save Project and Load Runtime. At the message about regenerating IO Scanner tag names, click OK.

Initial setup is finished, and PAC Display Runtime Basic opens in front of PAC Display Configurator, showing the sample HMI for the OptoEMU1. You can close Configurator (the one in back), but leave Runtime (the one in front) open. Continue with Chapter 2 to learn how to use the HMI.

Specifications

Overall Unit	
Power Requirements	100–240 VAC, 0.6 A
Communication	10/100 Mbps Ethernet network interface (RJ-45 connector)
Backup battery	Rechargeable (recharges whenever the unit has power), 3-year power-off data retention
Operating Temperature	0 to 60 °C
Storage Temperature	-40 to 85 °C
Humidity	0–95% humidity, non-condensing
Enclosure	NEMA Type 4X polycarbonate
SNAP-AIPM-3 Voltage inputs (each input)	
Recommended Input Range	85 to 250 VAC RMS
Input Over Range	To 275 volts
Maximum Input	300 V
Input Resistance – Single Ended	1 Megohm (NOTE: Because both channels share the same reference terminal, polarity must be observed when connecting the current channel.)
SNAP-AIPM-3 Current Inputs (each input)	
Input Range	0 to 10 AC amps RMS
Input Over Range	To 11 amps (Reading is not reliable over 11 A.)
Maximum Input	15 A continuous
AC Common Mode Rejection	> – 120 dB at 60 Hz
Maximum Operating Common Mode Voltage	250 VAC
Input Resistance – Single Ended	0.005 Ohm (NOTE: Because both channels share the same reference terminal, polarity must be observed when connecting the voltage channel.)

2: Monitoring Devices

Using the Main Window

NOTE: The sample HMI is designed to fully fit a monitor with a 1000 x 720 screen.

1. If the sample HMI is not already running, from the Start menu choose Programs > Opto 22 > PAC Project > PAC Display Runtime Basic.
2. If the HMI does not start running immediately, choose File > Open Project and navigate to the HMI (default location: C:\Program Files\Opto22\OptoEMU1\Power Monitor Display). Highlight `Power Monitor Display xp.tst` and click Open.

The OptoEMU1 Monitoring window opens:

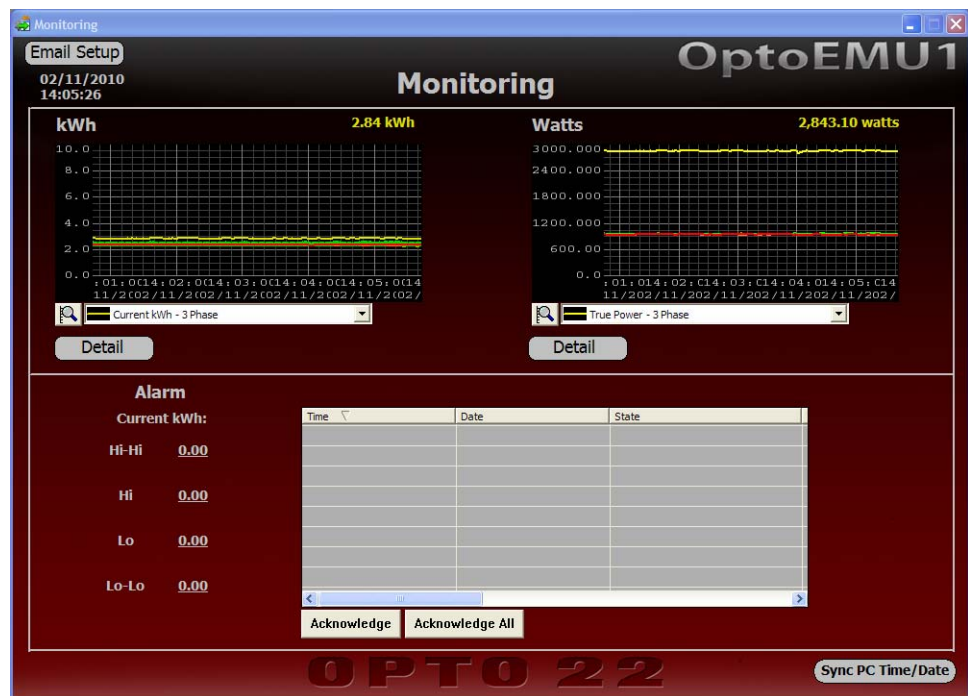

3. Since the OptoEMU1 begins recording data right away, click the Sync to PC Time/Date button in the bottom-right corner of the window to synchronize the OptoEMU1 with the computer.

The Monitoring window has three panels: kWh and Watts at the top, and Alarm at the bottom.

- Use **kWh** and **Watts** to monitor current energy usage (kilowatt-hours and true power).
- Use **Alarm** to define, view, and acknowledge alarms. (See [“Setting Up Alarms” on page 27.](#))

Viewing Current Energy Usage

The kWh and Watts panels show current energy usage. Data is updated every second. The value at the upper right always reflects 3-phase data. The kWh panel is shown below as an example; the Watts panel works in the same way.

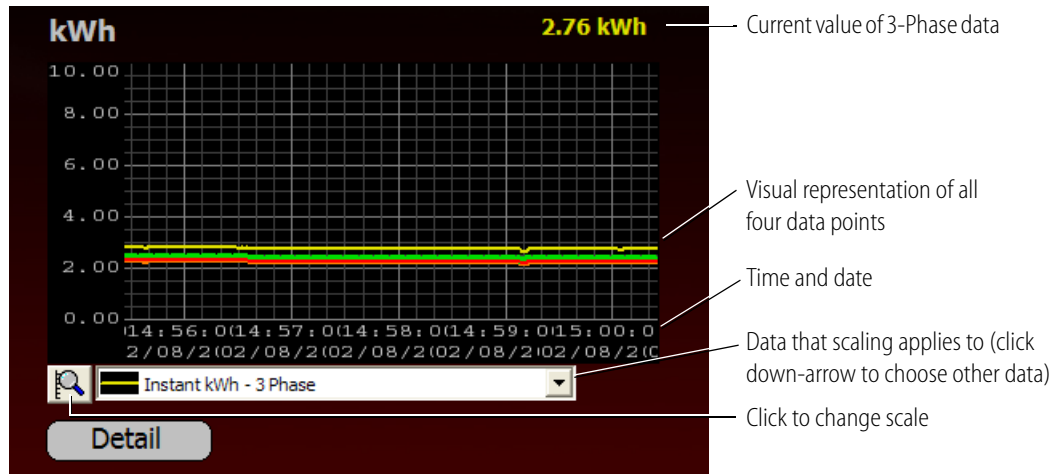

If you don't see all four lines, you may want to change the scale on the graph.

1. To change the scale on the graph, click the down arrow and choose the line for the data you want.

Yellow = Sum of phases A, B, and C

Orange = Phase A

Green = Phase B

Red = Phase C

2. Click the Scale button . Enter the scale values you want and click OK.

NOTE: This scale change applies only to the data for the line you've chosen.

3. For more, click the Detail button in the panel. For the kWh panel, see [“Viewing Historical kWh Data,”](#) below. For the Watts panel, see [“Viewing Historical Energy Data” on page 25.](#)

Viewing Historical kWh Data

Historical data is automatically saved on the PC. Here's how to view that data.

1. In the Monitoring window, click the Detail button in the kWh panel.

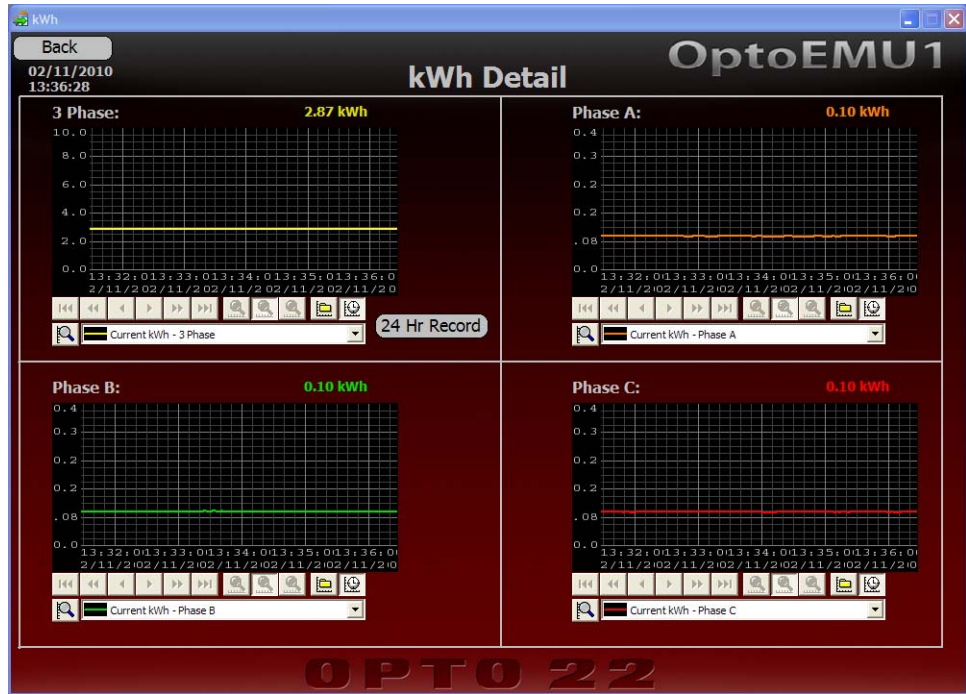

This window shows a panel for each of the three phases plus the sum. You can also get historical data from this window.

2. To see the total kWh for each hour within the most recent 24-hour period, click the 24 Hr Record button.

The screenshot shows the '24-Hour kWh' window with a table of hourly data. The table has columns for Index, Hours, and kWh/Hour. The data is as follows:

Index	Hours	kWh/Hour
0	15:00	2902.5833
1	14:00	2832.6514
2	13:00	2821.4766
3	12:00	2824.7051
4	11:00	2823.9460
5	10:00	2816.2197
6	9:00	2789.8140

A 'Close' button is located at the bottom of the window.

New data appears at the top of the table at index zero, at the end of the hour. To widen a column to fit the data, put your cursor on the right-hand edge of the column's title. When the

cursor changes to a plus sign, click and drag the column to the width you want. Click Close when finished.

3. To see historical data for one of the phases or the sum, click its historical trend button .

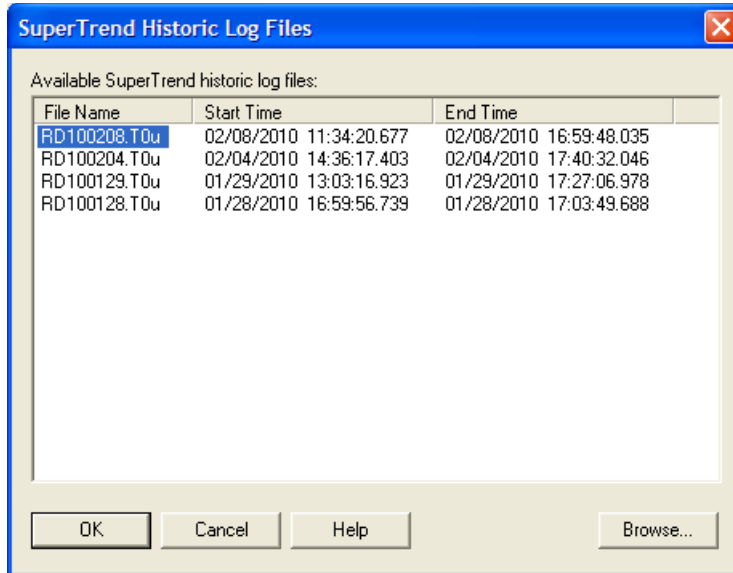

4. Highlight the log file or files you want to see and click OK. For multiple files, click the first file, hold down the SHIFT key, and click the last file. For non-contiguous files, hold down the CTRL key while you click each file.

The graph changes from current data to historical data.

5. Use the button bar to work with the historical trend graph:

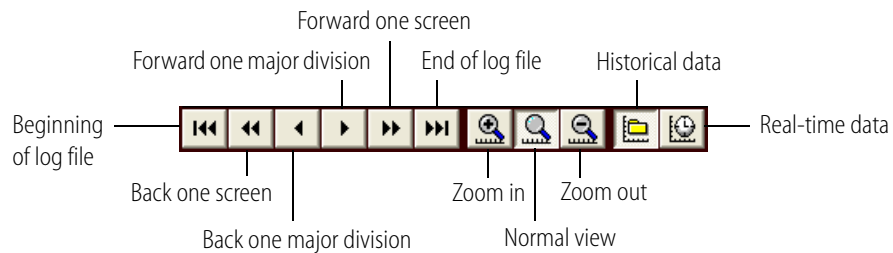



6. To see the value, time, and date at any point on the graph, click that point.

The two graphs at top show Volts and Current for each of the three phases, with color-coded numeric values. The bottom graph is a larger version of the Watts graph from the main window, also with color-coded numeric values for True Power and Power Factor.

You can also access historic logs from this window.

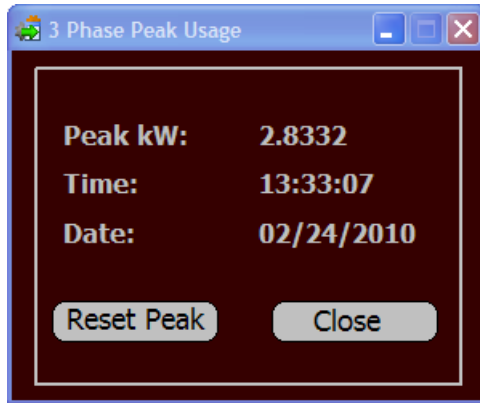
- To find the peak kilowatt usage of the day, click the Peak Usage button at the bottom right. A small dialog box opens showing the peak plus the time and date it happened.



- To reset the value for your next observation, click Reset Peak. Then click Close.
- To see historical data for a graph, click its historical trend button  and follow the same steps you used for the kWh graph (see page 24).

NOTE: If you click a point on the graph to see the value at that time and date, the value you see is for the line listed. To see the data point for a different line (Phase B, for example), click the down arrow and choose the line you want.

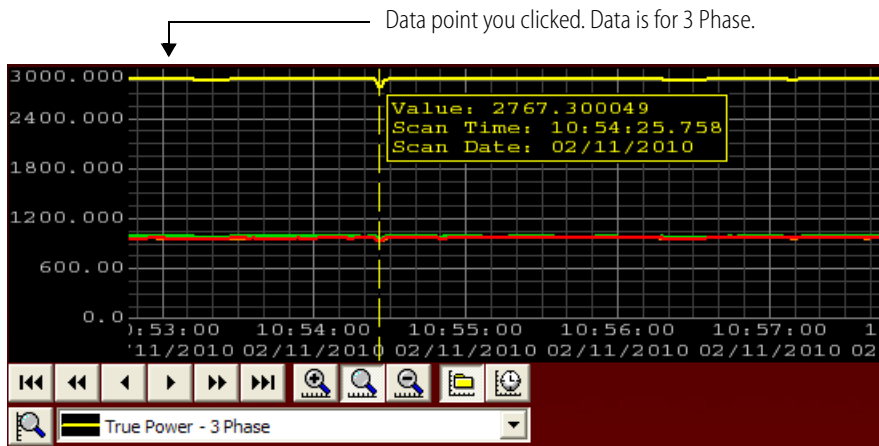

To see data for a different line, click the down arrow and choose the line. Then click the point on the graph.

- To return to the Monitoring window, click the Back button at the upper-left corner.

Using Alarms and Email Notification

Once you've monitored energy usage for a short while, you'll want to do more:

- Set up alarms you can see and acknowledge in the main Monitoring window.
- Define normal usage and set up email notification if usage is abnormal.

Setting Up Alarms

Alarms are set up in the Alarm panel of the Monitoring window. In the sample HMI, you will not receive email messages for alarms; instead, they appear in this window and can be acknowledged from here.

Alarms are based on Current kWh of the three phases. You can set up four alarms:

- HiHi alarms occur when the Current kWh value reaches or exceeds the HiHi value.
- Hi alarms occur when the Current kWh value reaches or exceeds the Hi value but is less than the HiHi value.
- Lo alarms occur when the Current kWh value is equal to or less than the Lo value but greater than the LoLo value.
- LoLo alarms occur when the Current kWh value is equal to or less than the LoLo value.

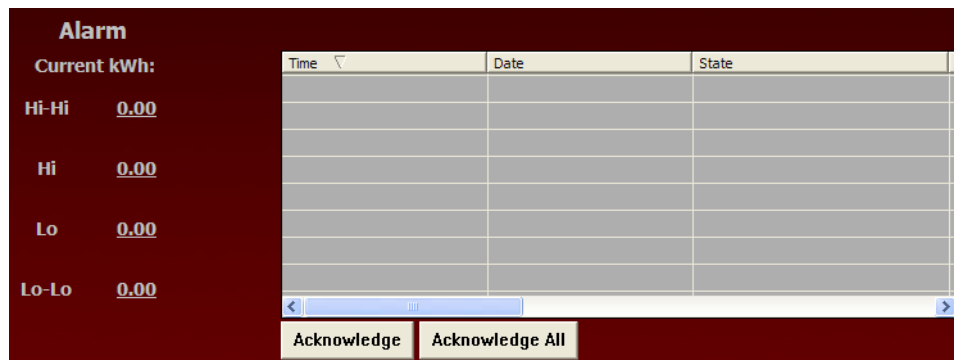

1. To set up alarms, click the numeric value field for the alarm you want to define.

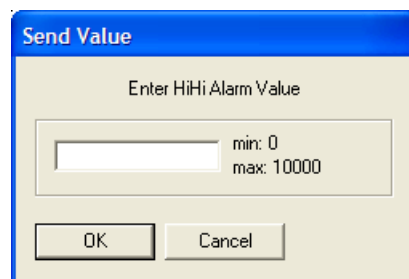

2. Enter the value for the alarm and click OK. Repeat for any other alarms you want to set.

Viewing and Acknowledging Alarms

When an alarm occurs, it is listed in the Monitoring window:

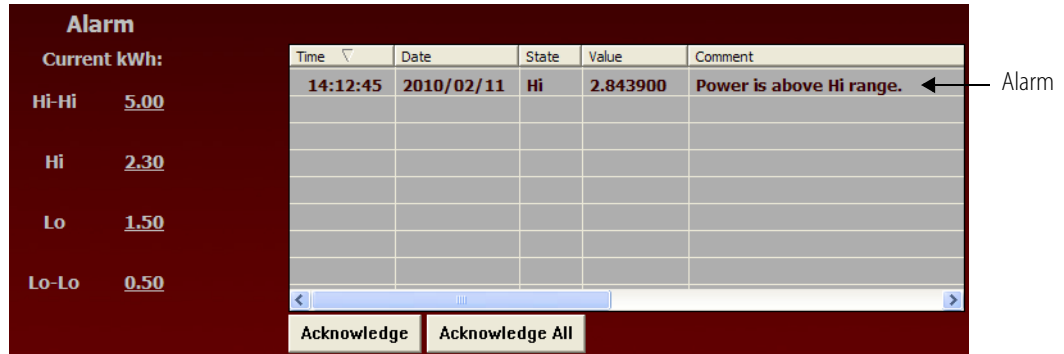

If you cannot see all the data, change the width of the columns to fit, or scroll to the right.

To acknowledge an alarm, highlight it and click the Acknowledge button. The alarm listing turns to pale orange.

Defining Expected Energy Use and Email Notification

If the device’s energy use increases faster than expected, the OptoEMU1 can email an alarm to someone. Follow these steps to define expected energy use and set up the email address.

1. In the Monitoring window, click the Email Setup button in the upper left.

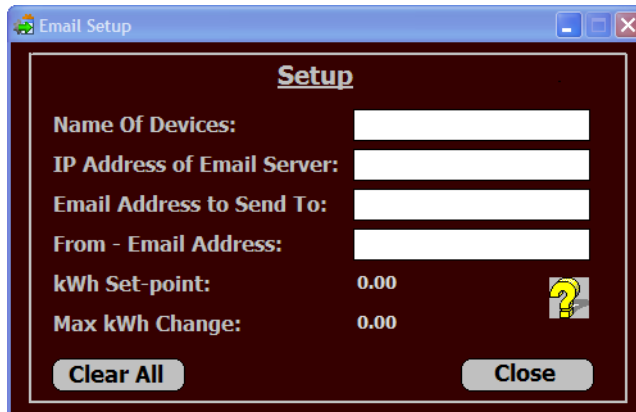

2. Complete the Setup dialog box as follows.

Name Of Devices	Enter a name for the device you’re monitoring.
IP Address of Email Server	Enter the IP address of the email server that the OptoEMU1 will use to send the email. If you don’t know the IP address, ask your network administrator. NOTE: The server must not require a password or authentication.
Email Address to Send To	Enter the email address of the person who will receive the email (example: jsmith@yourcompany.com)

From - Email Address	Enter a name that tells the person who receives the email where it is coming from (example: generator1). The email automatically includes the name of the device and date and time of the event.
kWh Setpoint	Enter a setpoint in kilowatt hours. This setpoint is the normal electrical energy use you expect from this device. Actual use above or below this value prompts the OptoEMU1 to calculate the change in kWh every second. If you don't know the normal energy use, watch it for awhile in the Monitoring window.
Max kWh Change	Enter the normally expected rise in energy use for this device, in kWh. Again, if you don't know the value to use, watch the energy usage change over time to see what is normal.

3. When you've finished entering information, click Close to return to the Monitoring window.

When an email is sent, the Monitoring window changes panel titles to red and shows the email in the Alarm panel:

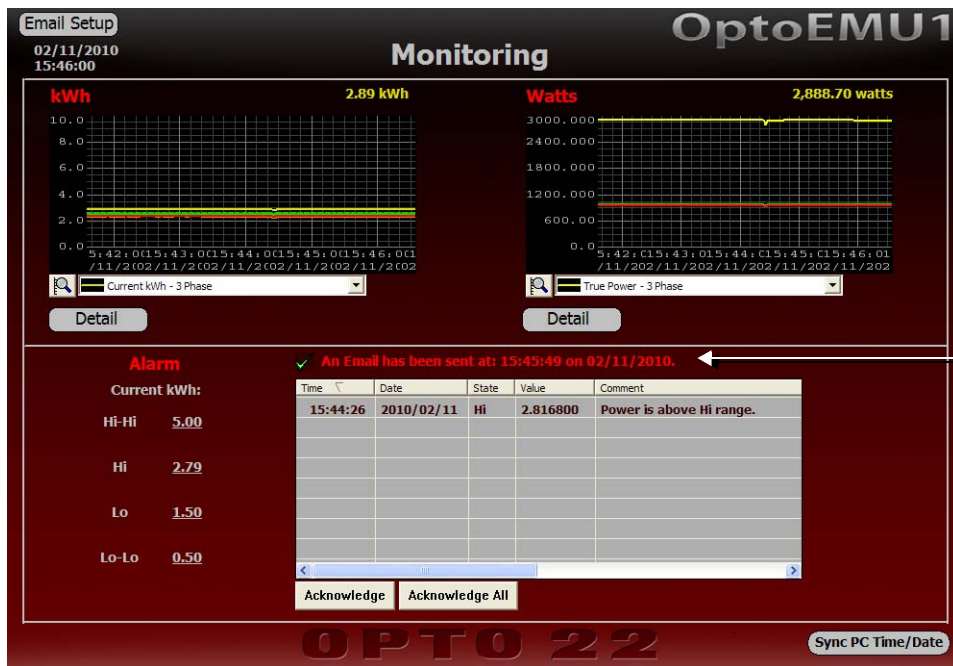

To clear the notice and return the window to normal, click the green check mark.

What's Next?

Now that you've gotten started with the sample control strategy and HMI, you'll probably want to adapt them to suit your own needs. All the tools to do so are readily available. The PAC Project Basic software included with your OptoEMU1 is a full version with complete documentation, and the OptoEMU1 unit is expandable.

- **To change the HMI**, choose Start > Programs > Opto 22 > PAC Project > PAC Display Configurator Basic. You can save the Power Monitor project file under a new name, play with it, and change it as you wish. For help, see the *PAC Display User's Guide* (in Start > Programs > Opto 22 > PAC Project > Manuals).
- **To monitor additional equipment or to control devices**, add the I/O modules required. For descriptions and specifications, see our website, www.opto22.com (click the Products tab, choose SNAP PAC System, and then choose Brains and I/O). A wide range of analog, digital, and serial I/O modules is available. You can add more modules to the OptoEMU1, and you can also add additional racks, brains, and I/O for an extended system, all controlled by the OptoEMU1's controller.

If you have questions about which products to use, contact our Pre-sales Engineers by phone (800-321-6786 or 951-695-3000) or by email (systemseng@opto22.com).

- **To modify the control strategy**, choose Start > Programs > Opto 22 > PAC Project > PAC Control Basic. Save the strategy in a new folder under a new name. Explore the Strategy Tree, which lists all the elements in the strategy—control engines, flowcharts, all kinds of variables, and all the I/O points. Also take a look at the flowcharts; they are largely self-documenting, so you can see what they do and how the logic flows. For help in using PAC Control, see the *PAC Control User's Guide* and the *PAC Control Command Reference* (to open the PDFs, choose Start > Programs > Opto 22 > PAC Project > Manuals).
- **Free training** on PAC Control and PAC Display is available at our headquarters in Temecula, California. See <http://www.opto22.com/site/training.aspx> for more information, or call 800-321-6786 and ask for Training.
- **Free product support** is included with your OptoEMU1. See “For Help” on page 1 for contact information.